

Improving organizational agility through ethical leadership, employee job satisfaction and Islamic OCB

Ardian Mustofa*, Heru Kurnianto Tjahjono

Doctoral of Management, Universitas Muhammadiyah Yogyakarta, Indonesia

* Corresponding author: ardian.mustofa.psc21@mail.umy.ac.id

Abstract

In the contemporary business realm, characterized by dynamic shifts and technological progress, agility has emerged as a vital concept to enable businesses to navigate and thrive amidst uncertainty and intensified competition. Key to fostering Agility is garnering comprehensive support from all stakeholders, notably organizational leaders and employees. This research aims to explore several factors contributing to Organizational Agility, including Ethical Leadership, Islamic OCB, and Employee Job Satisfaction. Adopting a quantitative methodology, the research focuses on employees and managers in the café and restaurant businesses in Yogyakarta, renowned for its dynamic nature and competitive environment. With a total sample of 179 managers and employees, participants were selected through purposive sampling criteria, targeting establishments operational for at least one year, employing a minimum of ten staff, and respondents with tenure exceeding six months in supervisory, managerial, or ownership capacities. Primary data collection utilized questionnaires, and structural equation modeling via AMOS software facilitated analysis. Results reveal a positive correlation between Ethical Leadership and Employee Job Satisfaction, Islamic OCB, and Organizational Agility. Additionally, Employee Job Satisfaction and Islamic OCB were found to impact Organizational Agility positively. Thus, integrating Islamic OCB into business practices offers a promising avenue for enhancing Agility, particularly in Muslim-majority regions.

Keywords: Ethical Leadership, Employee Job Satisfaction, Islamic OCB, Organizational Agility, Café and Restaurant Businesses

Introduction

In recent years, companies have been required to do two things, namely Agility (Busse and Weidner, 2020; Peng and Kim, 2020) and Ethics (Freire and Bettencourt, 2020; Qing et al. 2020). Companies must be agile in the sense of being able to keep pace with the times and market demand. On the other hand, ethical issues are also increasingly being considered by practitioners, social activists, and researchers. Henceforth, it is imperative for the organization to meticulously address the entitlements and responsibilities of all stakeholders, ensuring their thorough execution and fulfillment. Additionally, leaders are mandated to exemplify superior conduct, serving as paragons for organizational constituents while fostering profound respect toward them (Peng and Kim, 2020).

The process of organizing entails establishing connections and fostering partnerships among individuals who possess diverse experiences, different traits, and characters and bringing together the opinions of several people for a common goal. Ethics holds paramount importance within organizational settings, fostering an environment where individuals naturally gravitate towards mutual acceptance, respect, and support. Within organizational contexts, leaders must spearhead ethical practices, giving rise to a leadership paradigm known as Ethical Leadership (Qasim et al. 2020).

The leadership coveted by employees is leadership based on ethics (Qing et al. 2020). With leadership based on ethics, employees can work better and be able to increase company agility (Cornelio and Medina, 2020; Rulinawaty and Samboteng, 2020). In practice, the role of Ethical Leadership needs to be supported by other factors to increase agility, including Employee Job Satisfaction and Islamic OCB. The correlation described hinges upon the principles of Social Exchange Theory (Blau, 1986), positing that trust develops through the ethical treatment of individuals, particularly within organizations where leadership is perceived to be grounded in ethical principles (Brown et al. 2005; Engelbrecht et al. 2017).

Numerous recent research highlight that evolving global market dynamics and technological advancements necessitate companies to cultivate organizational Agility. Busse and Weidner (2020) emphasize that in this dynamic era, businesses encounter four essential conditions: Volatility, Uncertainty, Complexity, and Ambiguity (VUCA). These conditions necessitate companies to adopt a more proactive and agile approach in addressing market shifts, rapid technological advancements, and digitalization. Agility can be honed and sharpened in various ways, both internal and external. This research will explore more deeply the factors that can increase agility from the company's internal side.

Ethical Leadership and Islamic OCB are often overlooked internal factors in fostering organizational agility. Ethical Leadership embodies leading by example, a critical consideration for company leaders. Conversely, Islamic OCB integrates traditional OCB principles with Islamic teachings, emphasizing the importance of Taqwa (Piety). According to Islamic teachings, individuals are encouraged to enhance their Taqwa, which, in turn, enhances employees' performance. Individuals with higher levels of Taqwa are more likely to exhibit elevated levels of Islamic OCB (Kamil et al. 2014, 2015).

Previous research focused on the direct associations between Employee Job Satisfaction and Islamic OCB, with limited exploration of their mediating effects (Cornelio and Medina, 2020; Rulinawaty and Samboteng, 2020). Thus, to advance the current understanding of Organizational Agility, this research integrates Employee Job Satisfaction as a mediator alongside Islamic OCB. Achieving a comprehensive understanding of the proposed mediating role necessitates addressing all relevant dimensions in this research, which focuses on cafe and restaurant businesses in Yogyakarta.

The cafe and restaurant businesses in Yogyakarta play a significant role in the local economy, contributing to employment opportunities, tourism, and overall economic growth. Yogyakarta, known for its vibrant culinary scene and cultural heritage, attracts a steady flow of tourists and visitors, thereby fueling the demand for dining establishments. Despite facing challenges posed by the COVID-19 pandemic, the cafe and restaurant industry in Yogyakarta has demonstrated resilience and adaptability, continuing to thrive amidst adversity.

As shown in the research framework below, this research delves into the relationship between Ethical Leadership (EL) and its impact on enhancing Islamic OCB (IOCB), Employee Job Satisfaction (EJS), and Organizational Agility (OA) within the cafe and restaurant sector in Yogyakarta. Ethical Leadership, characterized by leaders' adherence to ethical principles and values, is pivotal in shaping organizational culture and fostering employee morale and engagement (Qasim et al. 2020). Employee Job Satisfaction, another variable examined in this research, reflects the extent to which employees feel fulfilled and content in their roles within cafe and restaurant establishments (Inegbedion et al. 2020). Additionally, Islamic OCB, which encompasses behaviors such as altruism, conscientiousness, and civic virtue guided by Islamic principles (Mustofa and Muafi, 2021), holds relevance in the context of Yogyakarta's predominantly Muslim population.

By scrutinizing these internal facets of cafe and restaurant businesses in Yogyakarta, this research seeks to elucidate their role in bolstering Organizational Agility, enabling establishments to navigate market uncertainties and capitalize on emerging opportunities effectively. The findings of this research endeavor are anticipated to offer valuable insights and recommendations for enhancing operational efficiency, fostering employee well-being, and driving sustainable growth within the cafe and restaurant sector in Yogyakarta.

Figure 1: Research Framework.

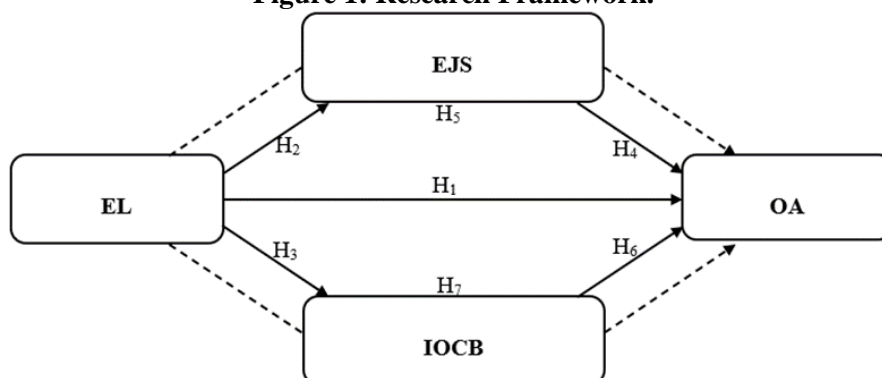

Literature Review

Organizational Agility

This research focuses on the capacity highlighted as Agility. Agility within a company or organization encompasses various attributes, including decentralization, flexibility, adaptability to the environment, and the capacity to adjust to evolving circumstances (Aljawarneh et al. 2021; Khairo et al. 2018). This capacity requires the role and involvement of company stakeholders, especially employees (Abbas and Kowang, 2020). Agility is a concept considered by many literatures to have a significant role in the sustainability of companies in this era (Cornelio and Medina, 2020; Rulinawaty and Samboteng, 2020).

In examining endeavors aimed at enhancing organizational agility, this research draws upon the Resource-Based View (RBV) theory, positing that a company's competitive advantage predominantly stems from the effective utilization of valuable resources within the organization (Barney, 1991). Valuable resources that will be analyzed further in this research focus on human resources, including leadership and OCB (Organizational Citizenship Behavior).

Linked to the concept of Agility is the "Agile Manifesto," which delineates fundamental values in agility: individual and interaction of processes and tools, software that functions through comprehensive documentation, customer collaboration through contract negotiation, and responding to changes by following a plan. Therefore, in realizing Agility, the role of a leader is needed. Leaders who achieve agility are those capable of effectively leading employees in fast-paced, constantly changing, and complex environments, requiring wise and practical actions (Busse and Weidner, 2020; Joiner and Josephs, 2007).

Agility within the company is designed to increase the company's ability to understand and anticipate changes in the business environment. Agility includes several aspects, namely Responsiveness to Changes, Competence, Flexibility, and Operational Speed (Zakeri et al. 2018). Companies that have agility means that they have several capabilities, namely adapting quickly to changes, predicting and identifying changes, responding to changes quickly, and responding flexibly to new demands for emerging services and adapting them to available resources and facilities (Melián et al. 2020).

Ethical Leadership

The discourse surrounding ethics and morality has been the subject of extensive scholarly inquiry. According to social learning theory, employees are inclined to emulate the behavior of their leaders in the execution of their duties. Therefore, ethical leaders will be able to form ethical employees and work better (Walumbwa et al. 2017). Abbas and Kowang (2020) stated that ethics, especially leadership ethics, is an essential factor in improving company performance.

Freire and Bettencourt (2020) contend that Ethical Leadership exhibits various characteristics such as attentiveness, fairness, reliability, and honesty. This assertion underscores the notion that Ethical Leadership encompasses not only ethical integrity

but also interpersonal dynamics. Ethical Leadership is also characterized by genuine, honest, kind, and caring leaders who are able to make fair decisions based on a set of organizational values (Qing et al. 2020). Meanwhile, Cansoy (2019) revealed several attributes of Ethical Leadership, namely integrity, accountability, awareness, motivating others, and making ethical decisions to influence others.

When discussing leadership, the core principle lies in trust, and trust towards leaders from employees can be cultivated when the leader exhibits ethical conduct (Peng and Kim, 2020). Ethical leaders possess the capability to guide their team members adeptly, thereby increasing the likelihood of fostering agility (Cornelio and Medina, 2020; Rulinawaty and Samboteng, 2020). While literature directly addressing the correlation between Ethical Leadership and Agility is limited, researchers generally concur that Ethical Leadership facilitates effective and swift mobilization of team members, thereby promoting agility (Busse and Weidner, 2020; Peng and Kim, 2020).

Akkaya and Tabak (2020) underline the pivotal role of effective leadership in shaping Organizational Agility. Hoff and Smith (2020) propose effective leadership as a solution to address Volatility, Uncertainty, Complexity, and Ambiguity (VUCA) conditions. Among the attributes of effective leadership conducive to fostering Organizational Agility is Ethical Leadership. Employees tend to value Ethical Leadership for its adherence to moral principles within the organization (Qing et al. 2020). Işık (2020) asserts that Ethical Leadership contributes to employee satisfaction and operational efficiency within the company. Numerous prior studies concur that Ethical Leadership positively influences employees, enhancing their well-being and satisfaction (Abbas and Kowang, 2020; Freire and Bettencourt, 2020; Kaffashpoor and Sadeghian, 2020; Qing et al. 2020).

On the other hand, Ethical Leadership is leadership that prioritizes example. Ethical Leadership must set a good example for employees so that they are able to motivate and encourage employees to work better. One form of employee overperformance is OCB. OCB is part of the Social Exchange, which states that individuals tend to repay other people or parties who provide benefits and benefits to them (Tepper and Taylor, 2003).

In several pieces of literature, it has been proven that Ethical Leadership can increase the OCB of employees (Aloustani et al. 2020; Arshad et al. 2021; Qasim et al. 2020). The most important aspect of building employee performance is the work climate (Arshad et al. 2021). A good work climate is created if all members of the organization, especially leaders, apply applicable ethics and norms (Arshad et al. 2021; Qasim et al. 2020). Based on this explanation, the hypotheses proposed are:

- H1** Ethical Leadership has a positive effect on Organizational Agility.
- H2** Ethical Leadership has a positive effect on Employee Job Satisfaction.
- H3** Ethical Leadership has a positive effect on Islamic Organizational Citizenship Behavior.

Employee Job Satisfaction

Employee Job Satisfaction is one of the keys to maintaining good performance in the company. Several kinds of literature prove the mediating role of Job Satisfaction in the influence of Ethical Leadership on Organizational Agility (Amirnejad, 2016; Omidvar et al. 2020). The mediation effect shows that Job Satisfaction can boost the role of Ethical Leadership in increasing Organizational Agility. Amirnejad (2016) found that the relationship between Leadership and Agility will be effectively realized if employees are satisfied with their work

Job satisfaction is a positive reflection in the form of emotions and behavior obtained by someone from their workplace (Inegbedion et al. 2020). This positive reflection must be maintained by the company continuously for the sake of the company's survival. Agility in the company can be achieved if employees have high job satisfaction because, with satisfaction, employees can provide better performance (Aljawarneh et al. 2021; Omidvar et al. 2020).

Abbas and Kowang (2020) underscore the significance of Job Satisfaction within organizations and propose strategies to foster it, such as cultivating a conducive work environment for employees. This assertion is corroborated by Gupta et al. (2019), who argue that Job Satisfaction indicates a camaraderie among employees, thereby positively influencing both employee and organizational performance.

Multiple scholarly works provide empirical evidence regarding the impact of Ethical Leadership on Employee Job Satisfaction (Freire and Bettencourt, 2020; Qing et al. 2020), as well as the influence of Job Satisfaction on Organizational Agility (Gupta et al. 2019; Omidvar et al. 2020). These findings substantiate and endorse the mediating function of Employee Job Satisfaction in the correlation between Ethical Leadership and Organizational Agility.

The key to increasing job satisfaction for employees and all elements of the company is to create a positive and comfortable work environment (Abbas and Kowang, 2020). Therefore, creating Agility can be started by establishing a positive environment so that employees are satisfied and able to perform better.

Several research have analyzed and proven the influence of Agility on Job Satisfaction (Gupta et al. 2019; Omidvar et al. 2020). However, this research will provide a different analysis, namely, the effect of Job Satisfaction on Organizational Agility. Amirnejad (2016) provides evidence supporting the beneficial impact of Job Satisfaction on enhancing Agility, along with highlighting the mediating function of Job Satisfaction in the connection between Leadership and Agility. The findings underscore the significance of employee satisfaction as a crucial factor within organizations, necessitating attention and fulfillment by companies. Additionally, the influence of Job Satisfaction on Agility was reaffirmed by Azmy, (2021; Moshabbaki et al. 2013). Based on this explanation, the hypotheses proposed are:

H4 Employee Job Satisfaction has a positive effect on Organizational Agility.

H5 Employee Job Satisfaction mediates the relationship between Ethical Leadership and Organizational Agility.

Islamic Organizational Citizenship Behavior

The willingness of employees to perform tasks outside of their official responsibilities is often termed OCB (Qasim et al. 2020). When employees carry out OCB with an Islamic religious approach, it is known as Islamic OCB or OCB from an Islamic perspective (Kamil et al. 2015). Islamic OCB is an important variable that often occurs mainly in Muslim countries but is still rarely analyzed. Islamic teachings strongly support OCB and are in line with the concept of piety (Noor and Abdullah, 2013; Supriyanto and Ekowati, 2020). Kazemipour et al. (2012) first made the connection between OCB and spirituality, but it is still general. Furthermore, Noor and Abdullah (2013) discuss OCB as a form of employee piety; the discussion has narrowed to the perspective of Islamic teachings. More specifically, Fasa, (2018; Kamil et al. 2014, 2015) developed OCB from an Islamic perspective. Finally, in 2021, Mustofa and Muafi (2021) developed the Islamic OCB concept. Islamic OCB is built from five dimensions, namely Altruism (*Ta'awun*), Civic Virtue, Sportsmanship (*Da'wah*), Conscientiousness (*Mujahadah*), and Courtesy (*Raf'al Haraj*). Some of these indicators are sourced from Mustofa and Muafi (2021). These five dimensions are also OCB dimensions but are developed from the point of view of Islamic teachings. With the development of Islamic OCB, employee awareness at work will be better. Islamic OCB is believed to be able to mediate the relationship between Ethical Leadership and Organizational Agility (Arshad et al. 2021; Qasim et al. 2020).

Research conducted by Kazemipour et al. (2012; Noor and Abdullah, 2013) revealed a favorable association between OCB and spirituality, encompassing ethics and discipline. However, the mediating influence of Islamic OCB on the correlation between Ethical Leadership and Organizational Agility still needs to be explored by researchers. The aspect of OCB that receives limited attention is Islamic OCB, which integrates OCB principles with Islamic teachings. According to Kamil et al. (2015), there exists a connection between OCB and *taqwa*, a manifestation of Islamic teachings. Individuals with elevated *taqwa* levels are more likely to demonstrate enhanced OCB, as highlighted by Kamil et al. (2014). The correlation between spirituality and OCB has been examined in prior research. Kazemipour et al. (2012; Noor and Abdullah, 2013) demonstrated a positive relationship between OCB and spirituality. Moreover, Supriyanto and Ekowati (2020) introduced the notion of OCB from an Islamic standpoint, revealing its association with spirituality and its beneficial impact on employee performance.

On the other hand, OCB has been proven by several previous literatures to increase Agility (Ahmadi et al. 2020; Zakeri et al. 2018). Organizations must have agile employees to achieve Agility. Therefore, it is essential to pay attention to the behavior that affects the agility of the workforce, one of which is OCB. Various literatures have widely discussed OCB, but there is an interesting concept related to OCB which has only recently been discussed by a few literatures, namely Islamic OCB (Kamil et al. 2015; Supriyanto and Ekowati, 2020).

The influence of OCB on Organizational Agility has been observed in various settings, as demonstrated by multiple research by Ahmadi et al. (2020; Zakeri et al. 2018), emphasizing the importance of Islamic OCB in fostering Organizational Agility. Abdolrasoul et al. (2014) explore OCB as a dimension of Servant Leadership, highlighting its potential to enhance Organizational Agility. These results suggest that

OCB serves as a factor capable of cultivating numerous favorable elements within the organization.

This research aims to contribute novelty by examining the impact of Islamic OCB on Organizational Agility. Islamic principles such as discipline, punctuality, trust, and honesty are highly congruent with the concept of Agility (Khan and Gul, 2020). Consequently, Islamic OCB is perceived to be deeply rooted in spiritual or Islamic values, guiding positive workplace behaviors (Fares and Noordin, 2016). Based on this explanation, the hypotheses proposed are:

- H6** Islamic Organizational Citizenship Behavior has a positive effect on Organizational Agility.
- H7** Islamic OCB mediates the relationship between Ethical Leadership and Organizational Agility.

Methodology

This research utilizes a survey-based methodology, adhering to a quantitative or positivist research framework (Creswell, 2010). Its primary aim is to examine the interconnectedness among Ethical Leadership, Employee Job Satisfaction, Islamic Organizational Citizenship Behavior (Islamic OCB), and Organizational Agility. This research focuses on a business industry characterized by dynamic fluctuations and heightened competition. The population in the study were cafes and restaurants in Yogyakarta. Employing a purposive sampling strategy, the research selects a sample based on specific criteria, including:

1. Cafes and restaurants with a minimum operational history of one year.
2. Cafes and restaurants with a workforce of at least ten employees.
3. Respondents who have served as supervisors, managers, or owners for a minimum tenure of six months.

The research sample for this research comprised 179 respondents employed in 85 cafes and restaurants in Yogyakarta. Data collection began in 2021 through the distribution of Google Form questionnaires using a Likert scale ranging from 1 (Strongly Disagree) to 5 (Strongly Agree) (Stockemer, 2019). The collected data were analyzed using Structural Equation Modeling (SEM) with the aid of AMOS software. According to Saunders et al. (2019; Tjahjono et al. 2021), SEM involves several stages that are statistically described and explained in the results section, including the normality test, outlier test, goodness of fit test, hypothesis test, and mediation effect test. This research focused on four primary variables: Ethical Leadership, Employee Job Satisfaction, Islamic OCB, and Organizational Agility. Each variable was assessed using specific measurement items below.

Ethical Leadership has eight items, as defined by Qing et al. (2020) that involve leaders conducting their personal lives ethically and listening to employees, fostering integrity and open communication. Employee Job Satisfaction has three items, according to Wang et al. (2020) which include satisfaction in receiving work assignments and pride in work, reflecting contentment, and a positive attitude toward

one's job. Islamic OCB has five items, according to Mustofa and Muafi (2021), which encompass altruism (*Ta'awun*) and civic virtue, emphasizing cooperation and ethical responsibilities. Lastly, Organizational Agility has five items, as described by Melián et al. (2020) that involve adapting to changes and predicting changes, highlighting the ability to adjust and foresee future developments in a dynamic environment.

Results

Respondent Characteristics

Respondents in this research were 179 employees at 85 cafes and restaurants in Yogyakarta. The characteristics of the respondents in this research were described in terms of several criteria, namely gender, age, and education. The description of the characteristics of the respondents is as follows:

Table 1: Respondents Characteristic

Demography	Frequency	Percentage
Gender		
Male	93	52 %
Female	86	48 %
Age		
15-30 years old	74	41 %
31-40 years old	68	38 %
41-50 years old	37	21 %
Education		
Elementary School		
Junior High School	21	12 %
Senior High School	73	41 %
Bachelor	85	47 %
Total Respondents	179	100 %

Source: Processed Data, 2022

Table 1 shows that the respondents in this research were primarily male, with as many as 93 respondents, aged between 15-30 years, as many as 74 respondents, and having the latest undergraduate education as many as 85 respondents.

Normality Test

A normality test is used to determine whether the data is normally distributed or not (Saunders et al. 2019). Normality testing is done by observing the value of the Critical Ratio (CR) of the data used; if the CR Multivariate data value is in the range of ± 2.58 , then the research data can be said to be expected. The results of the normality test of the data in this research can be seen in Table 2.

Table 2: Data Normality Test Results.

Variable	skew	c.r.	kurtosis	c.r.
OA1	-.814	-4.449	.086	.235
OA2	-1.060	-5.790	.645	1.760
IO5	-.835	-4.561	.344	.939
IO4	-.741	-4.048	.219	.598
EL8	-.689	-3.761	.540	1.474
EL7	-.753	-4.113	.314	.857
EL6	-.707	-3.860	.392	1.069
EL5	-.907	-4.953	.398	1.087
EL4	-.828	-4.524	.237	.647
IO1	-.596	-3.254	-.277	-.757
IO2	-.770	-4.205	-.018	-.049
IO3	-.775	-4.232	.184	.502
OA5	-.927	-5.064	.563	1.538
OA4	-1.086	-5.932	.427	1.167
OA3	-.749	-4.092	.209	.570
EJS3	-.811	-4.432	.629	1.717
EJS2	-1.070	-5.846	.519	1.418
EJS1	-.996	-5.442	.543	1.484
EL1	-.748	-4.086	.295	.805
EL2	-.863	-4.715	.434	1.184
EL3	-.632	-3.454	.153	.418
Multivariate			10.617	2.285

Source: Processed Data, 2022

Table 2 shows that the CR Multivariate is 2.285, which means it is between + 2.58 and – 2.58. According to the result, the data in this research can be said to be normally distributed.

Outlier Tests

Outlier tests are observations or data that have unique characteristics that look different from other observations and appear in the form of extreme values, both for a variable and for combination variables. The outliers can be evaluated using analysis of Multivariate Outliers seen from the Mahalanobis Distance (Tjahjono et al. 2021).

The Mahalanobis Distance is calculated using the Chi-Square on the Degree of Freedom of 21 indicators at the level of $p < 0.001$ with a Chi-Square value of 38.93. Analysis outliers have the Mahalanobis d-Square of 37.105, so it does not exceed the C-Square value of 38.93. From these results, it can be concluded that there are no outliers.

Confirmatory Analysis

Validity and Reliability Test

Confirmatory analysis is used to test the concept that was built using several measurable indicators. In confirmatory analysis, the first thing to look at is validity and reliability. Validity can be known through the Loading Factor value of each indicator. According to Hair et al. (2010), the minimum number of factor loading is

0.5 or, ideally, 0.7. As for the reliability test, construct reliability is good if the CR (Construct Reliability) value is > 0.7 and the VE (Variance Extracted) value is > 0.5 (Saunders et al. 2019). The results of the validity and reliability tests are shown in Table 3.

Table 3: Validity and Reliability Test

Variable	Indicator	Loading Factor	CR	VE
Ethical Leadership	EL1	0.761	0.9	0.6
	EL2	0.74		
	EL3	0.747		
	EL4	0.833		
	EL5	0.741		
	EL6	0.718		
	EL7	0.765		
	EL8	0.773		
Employee Job Satisfaction	EJS1	0.579	0.8	0.5
	EJS2	0.627		
	EJS3	0.531		
Islamic OCB	IO1	0.615	0.9	0.6
	IO2	0.655		
	IO3	0.963		
	IO4	0.964		
	IO5	0.55		
Organizational Agility	OA1	0.689	0.8	0.5
	OA2	0.62		
	OA3	0.652		
	OA4	0.608		
	OA5	0.82		

Source: Processed Data, 2022

Table 3 shows that all indicators have a Loading Factor > 0.5 so that all indicators are valid. Likewise, the CR value of each variable is > 0.7 , and the VE value is > 0.5 so that all variables are reliable.

Goodness of Fit

Furthermore, the conformity test of the confirmatory model was tested using the Goodness of Fit Index. In this research, several criteria were taken from each type of GOFI, namely Chi-Square, Probability, RMSEA, and GFI representing absolute fit indices, CFI and TLI representing Incremental Fit Indices then, PGFI and PNFI representing Parsimony Fit Indices (Saunders et al. 2019).

To increase the GOF value, it is necessary to modify the model that refers to the Modification Index by providing a covariance relationship or eliminating indicators that have a high MI (Modification Index) value. In the process of model modification, some indicators must be removed because they have a high MI (Modification Index) value, namely OI5 of Organizational Agility. The results of the confirmatory analysis can be seen in Table 4.

Table 4: Goodness of Fit Test Results

Goodness of Fit	Criteria	Cut-off value	Description
Chi-square	Small	195.08	Fit
Probability	≥ 0.05	0.055	Fit
RMSEA	≤ 0.08	0.032	Fit
GFI	≥ 0.90	0.905	Fit
CFI	≥ 0.90	0.986	Fit
TLI	≥ 0.90	0.984	Fit
PGFI	≥ 0.60	0.711	Fit
PNFI	≥ 0.60	0.795	Fit

Source: Processed Data, 2022

Table 4 shows that the Goodness of Fit has met all the criteria so that the model in this research can be said to be Fit.

Hypothesis Testing

The subsequent examination involves conducting a comprehensive Structural Equation Modeling (SEM) analysis of the whole model to evaluate the hypotheses formulated in this research (Saunders et al. 2019). The assessment of Regression Weights in this investigation is illustrated in Figure 2 and detailed in Table 5.

Figure 2: Path Analysis.

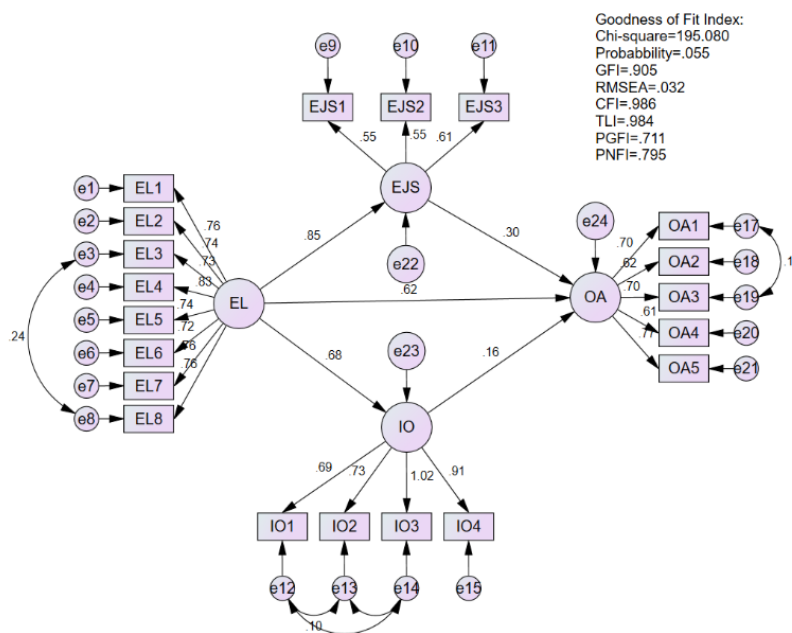

Source: Processed Data, 2022

The outcomes of hypothesis testing can be observed by examining the Critical Ratio (CR) and Probability (P) values derived from the data processing results. The direction of the relationship between variables can be seen from the Estimate; if the Estimate is positive, then the relationship between the variables is positive, whereas if the Estimate is negative, then the relationship is Negative. Furthermore, if the test

results show a CR value above 1.96 and a probability value (P) below 0.05/5 %, then the relationship between exogenous and endogenous variables is positive (Tjahjono et al. 2021). More details of the results of hypothesis testing are shown in Table 5.

Table 5: Regression Weight Test Results

	Estimate	CR	P	Result
H1 EL on OA	.671	4.093	0.000	Positive Significant
H2 EL on EJS	.732	8.474	0.000	Positive Significant
H3 EL on IO	1.006	9.049	0.000	Positive Significant
H4 EJS on OA	.373	1.971	0.049	Positive Significant
H6 IO on OA	.117	2.865	0.004	Positive Significant

Source: Processed Data, 2022

Table 5 illustrates that Ethical Leadership positively influences Organizational Agility, as indicated by the Estimate with a positive p-value < 0.05 at 0.000, thus supporting H1. Additionally, Ethical Leadership also demonstrates a positive impact on Employee Job Satisfaction, as evidenced by the Estimate with a positive p-value < 0.05 at 0.000, supporting H2. Furthermore, Ethical Leadership exhibits a positive effect on Islamic OCB, as indicated by the Estimate with a positive p-value < 0.05 at 0.000, supporting H3.

Table 5 further indicates that Employee Job Satisfaction positively impacts Organizational Agility, supported by the estimated value and a p-value < 0.05 at 0.049, thus supporting H4. Additionally, Islamic OCB is demonstrated to positively influence Organizational Agility, as evidenced by the estimated value and p-value < 0.05 at 0.000, thus supporting H6.

Mediation Effect Test

Testing in AMOS can be done through the bootstrapping and the results are seen from the positivity of the indirect effect between variables seen from the Indirect Effect-Two-Tailed Significance Table (Saunders et al. 2019). The results of the indirect effect analysis are shown in Table 6.

Table 6: Mediation Test Result

	P Value	Result
H5 EL - EJS - OA	0.023	Positive Mediation
H7 EL - IO - OA	0.002	Positive Mediation

Source: Processed Data, 2022

Table 6 demonstrates that the relationship between Ethical Leadership (EL) and Organizational Agility (OA) mediated by Employee Job Satisfaction (EJS) is significant, with a p-value of 0.023, indicating < 0.05. Thus, it can be inferred that Employee Job Satisfaction (EJS) mediates a positive association between Ethical Leadership (EL) and Organizational Agility (OA), supporting H5 in this research.

Moreover, Table 6 also indicates that the relationship between Ethical Leadership

(EL) and Organizational Agility (OA) mediated by Islamic OCB (IO) is significant, with a p-value of 0.002, signifying < 0.05 . Consequently, Islamic OCB (IO) mediates a positive relationship between Ethical Leadership (EL) and Organizational Agility (OA), thereby supporting H7 in this research.

Discussion

This research analyzes the relationship between Ethical Leadership in improving Islamic OCB and Organizational Agility in the cafe and restaurant business in Yogyakarta. This research also analyzes Employee Job Satisfaction as a mediating variable with Islamic OCB. Of the four variables in this research, seven hypotheses were formulated. The results of the analysis in this research indicate that the seven hypotheses are statistically supported.

Ethical Leadership and Organizational Agility

The findings from the initial hypothesis analysis reinforce the significance of Ethical Leadership, as evidenced by the empirical demonstration of its impact on Organizational Agility. These results align with previous research conducted by Abbas and Kowang, (2020; Freire and Bettencourt, 2020; Kaffashpoor and Sadeghian, 2020; Qing et al. 2020), which have also highlighted the influential role of Ethical Leadership. Ethical leaders demonstrate practical guidance to their team members, enhancing the likelihood of fostering agility within the organization.

The core attribute of effective leadership lies in establishing trust, a quality cultivated through ethical conduct by leaders, as highlighted by Peng and Kim (2020). Ethical leaders demonstrate the ability to guide their team members proficiently, consequently enhancing the prospects of nurturing Organizational Agility, as observed in research by Cornelio and Medina, (2020; Rulinawaty and Samboteng, 2020). Although there is limited direct literature addressing the correlation between Ethical Leadership and Agility, researchers generally concur that Ethical Leadership facilitates the efficient and prompt mobilization of team members, thereby fostering the development of agility within organizations, as indicated by research conducted by Busse and Weidner, (2020; Peng and Kim, 2020).

Ethics plays a crucial role in the culinary sector as it mirrors the quality of service provided to consumers while also enhancing the rapport between managers or owners and employees, as emphasized by Chatwani (2019). Furthermore, ethics underscore fairness and integrity, which are pivotal for fostering harmonious relationships among employees. This research corroborates that the implementation of Ethical Leadership by supervisors, managers, and owners can stimulate Organizational Agility, thereby facilitating adaptation to dynamic conditions, as evidenced by research conducted by Akkaya and Tabak, (2020; Busse and Weidner, 2020).

Ethical Leadership and Employee Job Satisfaction

In this research, the second hypothesis posits that Ethical Leadership positively influences Employee Job Satisfaction. The findings of the analysis affirm the validity of the first hypothesis, indicating that enhancing Ethical Leadership correlates with

increased Employee Job Satisfaction among employees serving in cafes and restaurants in Yogyakarta. This assertion is corroborated by several prior research, including those conducted by Abbas and Kowang, (2020; Freire and Bettencourt, 2020; Kaffashpoor and Sadeghian, 2020; Qing et al. 2020).

This research underscores the significance of ethical principles within leadership. Freire and Bettencourt (2020) posit that ethical leaders exhibit various traits, such as attentiveness, fairness, reliability, and honesty. This perspective highlights that Ethical Leadership encompasses interpersonal dynamics beyond mere moral conduct. Ethical leaders are characterized by their sincerity, integrity, benevolence, and compassion, enabling them to make equitable decisions grounded in organizational values (Qing et al. 2020).

In the context of employee satisfaction, ethics play an essential role. Ethical leadership promotes an organizational culture that is fair, transparent, and value-oriented. When employees feel they are treated fairly and supported in achieving their goals, their job satisfaction increases. Ethical leaders are attentive to the needs and interests of their employees. By building solid relationships, leaders can better understand what makes their employees feel valued and engaged, thus increasing job satisfaction.

Ethical Leadership and Islamic Organizational Citizenship Behavior

The third hypothesis of this research posits that Ethical Leadership positively influences Islamic OCB. The analysis findings substantiate the hypothesis, affirming that an elevation in Ethical Leadership correlates with an augmentation in implementing Islamic OCB among employees. These outcomes are corroborated by prior research, including research by Arshad et al. (2021; Kazemipour et al. 2012; Qasim et al. 2020).

The significance of Ethical Leadership extends beyond its impact on Employee Job Satisfaction to encompass its influence on Islamic OCB. Given the context of this research, these findings hold practical implications for company management, particularly within the culinary industry. Implementation involves integrating various facets of Ethical Leadership, such as ethically conducting themselves, listening to employee feedback, enforcing disciplinary measures for ethical violations, making impartial decisions, fostering trustworthiness, serving as moral role models, prioritizing employee welfare, and considering ethical factors in decision-making processes.

The application of Ethical Leadership within businesses, particularly within the culinary sector, has the potential to cultivate OCB. Ethical leadership fosters an organizational climate characterized by collaboration and reciprocal assistance, motivating employees to engage in voluntary actions that benefit both colleagues and the organization as a whole. Ethical leaders adeptly navigate conflicts with equity and respect, demonstrating attentiveness to employee needs. Consequently, this approach diminishes workplace discord and discontent, thereby enhancing employees' propensity to participate in voluntary activities that contribute to organizational objectives.

Employee Job Satisfaction and Organizational Agility

The fourth hypothesis in this research is that Employee Job Satisfaction positively influences Organizational Agility. The results of the analysis support the fourth hypothesis that Organizational Agility, apart from being improved by Ethical Leadership, can also be improved by Employee Job Satisfaction. The key to increasing Job Satisfaction for employees and all elements of the company is to create a positive and comfortable work environment (Abbas and Kowang, 2020). Therefore, creating agility can be started by establishing a positive environment so that employees are satisfied and able to perform better.

The outcomes indicated by Amirnejad (2016) elucidate the constructive role of job satisfaction in bolstering agility, alongside its mediating effect in the connection between leadership and agility. These findings underscore the centrality of employee satisfaction within organizational dynamics, highlighting its imperative fulfillment by companies. Additionally, Azmy, (2021; Moshabbaki et al. 2013) further corroborated the impact of job satisfaction on agility, contributing to a comprehensive understanding of this relationship.

Ethical Leadership is characterized by the adept handling of conflicts with equity and respect, coupled with a keen focus on addressing employees' requirements. Consequently, this approach diminishes instances of workplace discord and discontent, thereby fostering a greater propensity for employees to engage in voluntary actions that benefit the organization. Moreover, job satisfaction correlates with heightened productivity among employees, enabling organizations to adapt to fluctuations in market demands or customer preferences adeptly.

Islamic Organizational Citizenship Behavior and Organizational Agility

The results of this research further indicate that Islamic OCB can benefit Organizational Agility, corroborating the fifth hypothesis posited in this research. The demonstrated influence of OCB on agility, as evidenced by numerous instances in various scholarly works by Ahmadi et al. (2020; Zakeri et al. 2018), provides compelling evidence supporting the pivotal role of Islamic OCB in enhancing Organizational Agility. The alignment of Islamic principles such as discipline, punctuality, trust, and integrity with the ethos of agility by Khan and Gul (2020), underscores the robust foundation of Islamic OCB rooted in spiritual or Islamic values, thereby fostering positive behaviors within the organizational setting (Fares and Noordin, 2016).

The research by Abdolrasoul et al. (2014) highlights OCB as an aspect of Servant Leadership, demonstrating its effectiveness in bolstering Organizational Agility. These findings underscore the multifaceted benefits of OCB in fostering positive organizational dynamics and outcomes. Furthermore, implementing OCB in the culinary business context can yield significant positive impacts. Firstly, by promoting OCB among employees, leaders can strengthen team relationships and foster a more harmonious work environment. Employees who feel valued and are encouraged to engage for the organization's benefit proactively are more motivated and committed, thereby potentially enhancing productivity and service quality.

Secondly, OCB can help enhance organizational resilience when facing challenges and changes within the dynamic culinary industry. With employees willing to collaborate, take initiative, and quickly adapt to changes in the business environment, culinary businesses can be more responsive to evolving customer demands and market trends. Therefore, integrating the concept of OCB into leadership practices and work culture in the culinary industry can be an effective strategy to strengthen organizational performance and maintain competitive advantage.

The Mediation Role of Employee Job Satisfaction and Islamic Organizational Citizenship Behavior on The Relationship Between Ethical Leadership and Organizational Agility

This research also identifies the mediating effect of Employee Job Satisfaction on the association between Ethical Leadership and Organizational Agility, thereby corroborating the sixth hypothesis proposed. Several scholarly works provide empirical evidence of Ethical Leadership's impact on Job Satisfaction (Freire and Bettencourt, 2020; Qing et al. 2020), as well as the influence of Job Satisfaction on Organizational Agility (Gupta et al. 2019; Omidvar et al. 2020). This supports the notion of Job Satisfaction as a mediator in the relationship between Ethical Leadership and Organizational Agility.

Moreover, Islamic OCB is posited to mediate the correlation between Ethical Leadership and Organizational Agility (Arshad et al. 2021; Qasim et al. 2020). The current investigation also reveals the mediating role of Islamic OCB in the association between Ethical Leadership and Organizational Agility, thus validating the seventh hypothesis. Islamic OCB is comprised of dimensions such as Altruism (*Ta'awun*), Civic Virtue, Sportsmanship (*Da'wah*), Conscientiousness (*Mujahadah*), and Courtesy (*Raf'al Haraj*) by Mustofa and Muafi (2021), is regarded as a potential mediator in enhancing Organizational Agility within the culinary business context.

Identifying Employee Job Satisfaction and Islamic OCB as mediators between Ethical Leadership and Organizational Agility underscores the importance of fostering positive work environments and aligning organizational values with ethical principles. In the culinary industry, where teamwork, adaptability, and customer satisfaction are paramount, cultivating job satisfaction and adherence to Islamic OCB dimensions can contribute significantly to organizational success. By recognizing and leveraging these mediating factors, culinary businesses can enhance employee engagement, operational efficiency, and overall agility, thus gaining a competitive edge in the market.

Implications

This research examines the correlation among four variables, namely Ethical Leadership, Employee Job Satisfaction, Islamic OCB, and Organizational Agility among café and restaurant businesses in Yogyakarta. The findings of this analysis reveal that the data presented in Tables 5 and 6 provide substantial evidence supporting the hypotheses that Ethical Leadership (EL) positively influences Organizational Agility (OA), Employee Job Satisfaction (EJS), and Islamic Organizational Citizenship Behavior (Islamic OCB), as indicated by significant p-

values (< 0.05). Specifically, Ethical Leadership has a direct positive impact on Organizational Agility ($p < 0.000$), Employee Job Satisfaction ($p < 0.000$), and Islamic OCB ($p < 0.000$), thus supporting H1, H2, and H3, respectively. Additionally, Employee Job Satisfaction positively impacts Organizational Agility ($p = 0.049$), and Islamic OCB also positively influences Organizational Agility ($p < 0.000$), supporting H4 and H6 respectively. Furthermore, the mediation analysis in Table 6 reveals that Employee Job Satisfaction and Islamic OCB significantly mediate the relationship between Ethical Leadership and Organizational Agility, with p-values of 0.023 and 0.002, respectively, thereby supporting H5 and H7. These findings underscore the critical role of Ethical Leadership in enhancing both Organizational Agility directly and indirectly through its positive effects on Employee Job Satisfaction and Islamic OCB.

This research emphasizes the importance of Agility in the company, especially for companies that have intense market competition. Agility includes five aspects, namely adapting to changes, predicting changes, identifying changes, responding quickly to changes, and responding flexibly to new demands for services that arise, adapting them to the resources and means available. To improve agility, this research recommends three internal aspects of the company, namely improving Ethical Leadership, increasing Islamic OCB, and increasing Employee Job Satisfaction. These three aspects have been empirically proven to increase Organizational Agility, especially in café and restaurant businesses.

Practical Implications for Asian Business

The significance of agility or adaptability within businesses has garnered increasing recognition worldwide, with organizations acknowledging its importance in navigating dynamic work environments. Business agility entails swiftly responding to internal and external changes while maintaining focus and momentum. Enhancing Organizational Agility involves addressing challenges from a constantly evolving and uncertain business landscape. Central to achieving agility is the adoption of appropriate strategies, including the selection of competent leaders. Ethical leadership is pivotal in fostering agility, as it cultivates trust and confidence among employees, enhancing organizational responsiveness (Cornelio and Medina, 2020; Rulinawaty and Samboteng, 2020).

Employees who join agile organizations expect policies and leaders to be supportive and fair and that the company will operate ethically and be socially responsible. This research emphasizes the importance of ethics in leadership. Freire and Bettencourt (2020) argue that ethical leaders have several characteristics, including being considerate, fair, reliable, and honest. Ethical leadership is also characterized by genuine, honest, kind, and caring leaders who can make fair decisions based on organizational values (Qing et al. 2020). The role of Ethical Leadership is huge; besides influencing Employee Job Satisfaction, it has also been proven to affect Islamic OCB. Improved and Ethical Leadership styles can determine Employee Satisfaction and Performance, increasing Agile Behavior and OCB.

Good leadership treatment makes employees feel valued. This feeling of worth can increase OCB so that employee satisfaction and performance increase effectively and

efficiently. OCB is a voluntary action of an individual driven by the hope of getting benefits, which is a combination of intrinsic and extrinsic satisfaction. Usually, these benefits are received from others. Various OCB Islamic values are compatible with Agility, such as discipline, respect for time, trust, and honesty (Khan and Gul, 2020). Therefore, Islamic OCB is believed to have a stronger foundation, namely spiritual or Islamic values, in underlying positive actions at work to create a positive environment and be liked by employees (Fares and Noordin, 2016). Islamic OCB is believed to be able to exert influence between Ethical Leadership and Organizational Agility (Arshad et al. 2021; Qasim et al. 2020).

These findings hold profound implications for café and restaurant businesses, particularly in Asia, where rapid changes and intense competition characterize the industry. By emphasizing the importance of Ethical Leadership and fostering Employee Job Satisfaction and Islamic OCB, businesses can cultivate an environment conducive to agility, enabling them to navigate uncertainties and capitalize on emerging opportunities effectively. Moreover, the research underscores the unique cultural context of Muslim countries, where Islamic values and principles play a significant role in shaping organizational behavior and performance. As such, integrating Islamic OCB into business practices represents a valuable approach for businesses in Muslim-majority countries to enhance their agility and competitive advantage.

Overall, the findings of this research provide valuable insights for café and restaurant businesses in Asia, offering practical implications for organizational leadership and management practices. By leveraging Ethical Leadership, promoting Employee Job Satisfaction, and embracing Islamic principles, companies can position themselves for sustained success in today's dynamic and competitive landscape.

References

- Abbas, A. and Kowang, T. O. (2020) 'Impact of Ethical Leadership and Islamic Work Ethics on Employee Commitment and Job Satisfaction', *Journal of Research in Psychology*, 2(2), pp. 47-58. Available at: <https://doi.org/10.31580/jrp.v2i2.1601> (Accessed: 12 August 2024).
- Abdolrasoul, H. S., Zare, F., Nematollahi, K. and Avatefi, E. (2014) 'The role of servant leadership in organizational agility: A case study in Fars Social Security Organization', *European Online Journal of Natural and Social Sciences: Proceedings*, 2(3(s)), pp. 2935.
- Ahmadi, G. K., Sayadi, T. H., Bakhtiyari, Z. and Ahang, F. (2020) 'The Effect of Organizational Citizenship Behavior on Workforce Agility', *Journal of Development & Evolution Management*, 1398(special issue), pp. 199–207.
- Akkaya, B. and Tabak, A. (2020) 'The Link between Organizational Agility and Leadership: A Research in Science Parks', *Academy of Strategic Management Journal*, 19(1), pp. 1–17.
- Aljawarneh, N., Taamneh, M., Alhndawi, N., Alomari, K. and Masad, F. (2021) 'Fog computing-based logistic supply chain management and organizational agility: The mediating role of user satisfaction', *Uncertain Supply Chain Management*, 9(3), pp. 767–778.
- Aloustani, S., Atashzadeh, S. F., Zagheri, T. M., Nasiri, M., Barkhordari, S. M. and Skerrett, V. (2020) 'Association between ethical leadership, ethical climate and organizational citizenship behavior from nurses' perspective: A descriptive correlational study',

- BMC Nursing*, 19(1), p. 15. Available at: <https://doi.org/10.1186/s12912-020-0408-1> (Accessed: 12 August 2024).
- Amirnejad, G. (2016) 'The Casual Relationship of Organizational Leadership with Organizational Agility: The Mediating Role of Job Satisfaction and Organizational Commitment in Employees of National Iranian Drilling Company', *Journal of Industrial and Organizational Psychology Studies*, 2(2), pp. 105–122. Available at: <https://doi.org/10.22055/jiops.2017.23788.1063> (Accessed: 12 August 2024).
- Arshad, M., Abid, G. and Torres, F. V. C. (2021) 'Impact of prosocial motivation on organizational citizenship behavior: The mediating role of ethical leadership and leader–member exchange', *Quality & Quantity*, 55(1), pp. 133–150. Available at: <https://doi.org/10.1007/s11135-020-00997-5> (Accessed: 12 August 2024).
- Azmy, A. (2021) 'The Effect of Employee Engagement and Job Satisfaction on Workforce Agility Through Talent Management in Public Transportation Companies', *Media Ekonomi dan Manajemen*, 36(2), pp. 212–229.
- Barney, J. (1991) 'Firm Resources and Sustained Competitive Advantage', *Journal of Management*, 17(1), pp. 99–120. Available at: <https://doi.org/10.1177/014920639101700108> (Accessed: 12 August 2024).
- Blau, P. M. (1986) *Exchange and Power in Social Life*. 2nd edn. Routledge. Available at: <https://doi.org/10.4324/9780203792643> (Accessed: 12 August 2024).
- Brown, M. E., Treviño, L. K. and Harrison, D. A. (2005) 'Ethical Leadership: A Social Learning Perspective For Construct Development And Testing', *Organizational Behavior and Human Decision Processes*, 97(2), pp. 117–134. Available at: <https://doi.org/10.1016/j.obhdp.2005.03.002> (Accessed: 12 August 2024).
- Busse, R. and Weidner, G. (2020) 'A Qualitative Investigation On Combined Effects Of Distant Leadership, Organizational Agility And Digital Collaboration On Perceived Employee Engagement', *Leadership & Organization Development Journal*, 41(4), pp. 535–550. Available at: <https://doi.org/10.1108/LODJ-05-2019-0224> (Accessed: 12 August 2024).
- Cansoy, R. (2019) 'The Relationship between School Principals' Leadership Behaviours and Teachers' Job Satisfaction: A Systematic Review', *International Education Studies*, 12(1), pp. 37–52.
- Chatwani, N. (2019) *Organisational Agility: Exploring the Impact of Identity on Knowledge Management*. Springer.
- Cornelio, J. and Medina, E. (2020) 'The prosperity ethic: The rise of the new prosperity gospel', in *Routledge International Handbook of Religion in Global Society*. 1st edn. Routledge, p. 12.
- Creswell, J. W. (2010) *Research Design: Pendekatan Kualitatif, Kuantitatif dan Mixed*. 1st edn. Yogyakarta: Pustaka Pelajar.
- Engelbrecht, A. S., Heine, G. and Mahembe, B. (2017) 'Integrity, Ethical Leadership, Trust And Work Engagement', *Leadership & Organization Development Journal*, 38(3), pp. 368–379. Available at: <https://doi.org/10.1108/LODJ-11-2015-0237> (Accessed: 12 August 2024).
- Fares, D. and Noordin, K. (2016) 'Islamic spirituality, organizational commitment, and organizational citizenship behavior: A proposed conceptual framework', *Middle East Journal of Business*, 11(2), pp. 28–37.
- Fasa, M. I. (2018) *Model Pengembangan Organizational Citizenship Behavior (OCB) Karyawan Berbasis Nilai Islam* [Doctoral Thesis]. Universitas Islam Negeri Sunan Kalijaga. Available at: <https://digilib.uin-suka.ac.id/id/eprint/34806/> (Accessed: 12 August 2024).
- Freire, C. and Bettencourt, C. (2020) 'Impact of ethical leadership on job satisfaction: The mediating effect of work–family conflict', *Leadership & Organization Development Journal*, 41(2), pp. 319–330. Available at: <https://doi.org/10.1108/LODJ-07-2019-0338> (Accessed: 12 August 2024).

- Gupta, S., Kumar, S., Kamboj, S., Bhushan, B. and Luo, Z. (2019) 'Impact of IS agility and HR systems on job satisfaction: An organizational information processing theory perspective', *Journal of Knowledge Management*, 23(9), pp. 1782–1805.
- Hair, J. F., Black, B., Barry, J. B., William, C. B. and Rolph, E. A. (2010) *Multivariate Data Analysis: Global Edition*. 7th edn. Pearson Education. Available at: <https://www.pearson.com/uk/educators/higher-education-educators/program/Hair-Multivariate-Data-Analysis-Global-Edition-7th-Edition/PGM916641.html> (Accessed: 12 August 2024).
- Hoff, D. F. and Smith, D. E. (2020) 'Leadership and Learning Agility: A Lifelong Journey for W. Warner Burke', *The Journal of Applied Behavioral Science*, 56(4), pp. 492–502.
- Inegbedion, H., Inegbedion, E., Peter, A. and Harry, L. (2020) 'Perception of workload balance and employee job satisfaction in work organisations', *Heliyon*, 6(1), p. e03160. Available at: <https://doi.org/10.1016/j.heliyon.2020.e03160> (Accessed: 12 August 2024).
- Işık, A.N. (2020) 'Ethical leadership and school effectiveness: The mediating roles of affective commitment and job satisfaction', *International Journal of Educational Leadership and Management*, 8(1), pp. 60–87. <https://doi.org/10.17583/ijelm.2020.4114> (Accessed: 12 August 2024).
- Joiner, B. and Josephs, S. (2007) 'Leadership agility: Five levels of mastery for anticipating and initiating change', *Reflections: The SoL Journal*, 8(1), pp. 44–51.
- Kaffashpoor, A. and Sadeghian, S. (2020) 'The effect of ethical leadership on subjective wellbeing, given the moderator job satisfaction (a case study of private hospitals in Mashhad)', *BMC Nursing*, 19(1), p. 111. <https://doi.org/10.1186/s12912-020-00496-w> (Accessed: 12 August 2024).
- Kamil, N.M., Sulaiman, M., Selladurai, S. and Khalid, N. (2015) 'The impact of spirituality and social responsibility on organizational citizenship behaviour from the Islamic perspective: Empirical investigation of Malaysian businesses', *Malaysian Journal of Communication*, 31(1), pp. 59–80.
- Kamil, N.M., Sulaiman, M.B., Osman-Gani, A. and Ahmad, K. (2014) 'Investigating the dimensionality of organisational citizenship behaviour from Islamic perspective (OCBIP): Empirical analysis of business organisations in South-East Asia', *Asian Academy of Management Journal*, 19(1), pp. 19–46.
- Kazempour, F., Mohamad, A.S. and Pourseidi, B. (2012) 'Relationship between workplace spirituality and organizational citizenship behavior among nurses through mediation of affective organizational commitment', *Journal of Nursing Scholarship*, 44(3), pp. 302–310.
- Khairo, A.T., Saleh, A.N.M. and Mustafa, S.Z. (2018) 'Marketing mix strategies and its impact on organizational performance efficiency in the Jordanian Company for Investment and Supply-Safeway: An empirical study', *Social Science Research Network*. <https://doi.org/10.2139/ssrn.3267305> (Accessed: 12 August 2024).
- Khan, A.A. and Gul, A. (2020) 'Interactive effects of paternalistic leadership and Islamic work ethics on employees' psychological safety: Evidence from Pakistan', *Journal of Islamic Business and Management*, 10(1), pp. 1–18.
- Melián, A.L., Domínguez, F.C. and Martín, S.J.D. (2020) 'The role of the human dimension in organizational agility: An empirical study in intensive care units', *Personnel Review*, 49(9), pp. 1945–1964. <https://doi.org/10.1108/PR-08-2019-0456> (Accessed: 12 August 2024).
- Moshabbaki, E.A., Vahdati, H. and Moosavinejad, S.H. (2013) 'Improve the level of job satisfaction using emotional intelligence and organizational agility', *Quarterly Journal of Public Organizations Management*, 1(4), pp. 49–60.
- Mustofa, A. and Muafi, M. (2021) 'The influence of situational leadership on employee performance mediated by job satisfaction and Islamic organizational citizenship behavior', *International Journal of Research in Business and Social Science*, 10(1), pp. 95–106. <https://doi.org/10.20525/ijrbs.v10i1.1019> (Accessed: 12 August 2024).

- Noor, H.M. and Abdullah, Y.A. (2013) 'Urban residents' awareness and readiness for sustainable transportation case study: Shah Alam, Malaysia', *Procedia-Social and Behavioral Sciences*, 105(1), pp. 632–643.
- Omidvar, A., Zahed Babelan, A., Moeinikia, M. and Khaleghkhah, A. (2020) 'The relationship between organizational agility and innovative work behaviors with job satisfaction of secondary school teachers in Ardebil', *Journal of School Psychology*, 9(4), pp. 47–59.
- Peng, A.C. and Kim, D. (2020) 'A meta-analytic test of the differential pathways linking ethical leadership to normative conduct', *Journal of Organizational Behavior*, 41(4), pp. 348–368.
- Qasim, M., Rizvi, T.H. and Irshad, M. (2020) 'Impact of ethical leadership on task performance and organizational citizenship behavior: Moderating role of Islamic work ethics', *Journal of Management and Research*, 7(2), pp. 166-193. <https://doi.org/10.29145/jmr/72/070206> (Accessed: 12 August 2024).
- Qing, M., Asif, M., Hussain, A. and Jameel, A. (2020) 'Exploring the impact of ethical leadership on job satisfaction and organizational commitment in public sector organizations: The mediating role of psychological empowerment', *Review of Managerial Science*, 14(6), pp. 1405–1432. <https://doi.org/10.1007/s11846-019-00340-9> (Accessed: 12 August 2024).
- Rulinawaty, S.A. and Samboteng, L. (2020) 'Leading agile organization: Can Indonesian bureaucracy become agile?', *Journal of Talent Development and Excellence*, 12(3s), pp. 330–338.
- Saunders, M.N.K., Lewis, P. and Thornhill, A. (2019) *Research methods for business students*. 8th edn. Pearson Education Limited.
- Stockemer, D. (2019) *Quantitative methods for the social sciences: A practical introduction with examples in SPSS and Stata*. 1st edn. Springer International Publishing. <https://doi.org/10.1007/978-3-319-99118-4> (Accessed: 12 August 2024).
- Supriyanto, A.S. and Ekowati, V.M. (2020) 'Spiritual leadership and Islamic organizational citizenship behavior: Examining mediation-moderated process', *International Journal of Innovation, Creativity and Change*, 13(3), pp. 166-185.
- Tepper, B.J. and Taylor, E.C. (2003) 'Relationships among supervisors' and subordinates' procedural justice perceptions and organizational citizenship behaviors', *Academy of Management Journal*, 46(1), pp. 97–105.
- Tjahjono, H.K., Basuki, A.T. and Palupi, M. (2021) *Aplikasi SEM dalam studi perilaku organisasional*. UPP STIM YKPN.
- Walumbwa, F.O., Hartnell, C.A. and Misati, E. (2017) 'Does ethical leadership enhance group learning behavior? Examining the mediating influence of group ethical conduct, justice climate, and peer justice', *Journal of Business Research*, 72(1), pp. 14–23.
- Wang, W., Wang, Y., Zhang, Y. and Ma, J. (2020) 'Spillover of workplace IT satisfaction onto job satisfaction: The roles of job fit and professional fit', *International Journal of Information Management*, 50(1), pp. 341–352.
- Zakeri, M., Asadi, E., Rostami, N. and Davarzani, M. (2018) 'The effect of organizational citizenship behavior on enhancing the organizational agility by emphasizing the mediating role of the success of organizational resource planning system (Case study: One of the industrial organizations in defense field)', *Military Management Quarterly*, 17(68), pp. 1–31.



All papers are published under the Creative Commons Attribution 4.0 International (CC BY 4.0). For more details, visit <https://creativecommons.org/licenses/by-nc/4.0/>.